

Stepping Servo Motor

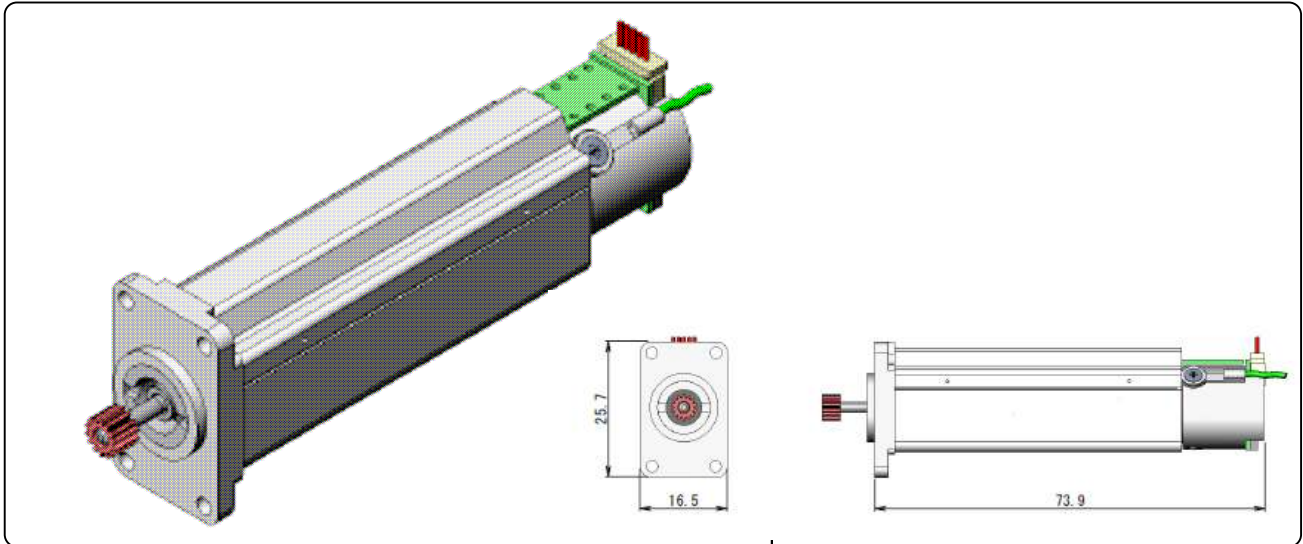

Features

- Stepping Motor with Magnetic Encoder
- Servo Control / 5120pulse/rev
- Low Inertia / High speed positioning
- Small size 16.5 × 25.7mm
- The length can variable depend on necessary torque (53.9~73.9mm)
- Low-Priced in comparison with AC servo motor

<Accuracy>

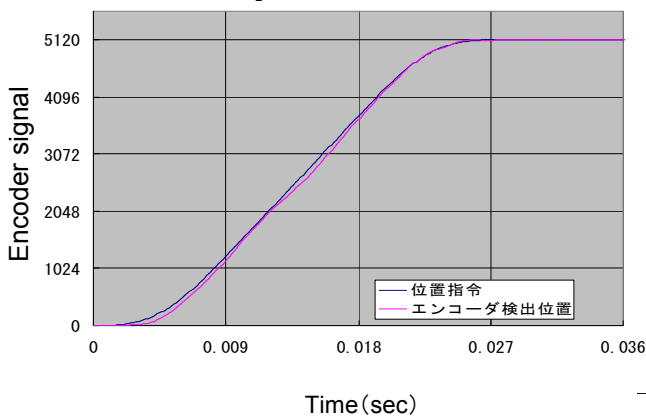

<Torque-Speed>

